



Description

The Natural gas module is a battery operated detection device designed for detection of natural gas (methane) in concentrations below 100% LEL (4.4% CH₄ in air). This module is not suitable for propane and butane detection. The sensor is equipped with test button as well as an audible alarm option realized with embedded buzzer.

The heart of the device is an MP-7227 MEMS pellistor sensor which allows for low power operation on standard AA type batteries.

The module is equipped with visual (LED) and audible (buzzer) alarms to inform of potential gas leakage as well as transmit data related to actual state of the module and concentration of gas if the module is connected to external receiver working with serial RS232 standard.

The estimated maintenance-free operation on 2xAA (2600mAh) batteries is 6 months.

Power consumption

The typical power consumption of the module is <0.6mA on average, with 50mA peak power consumption at 3V power supply.

Module operation

The Natural gas module monitors the concentration of methane in air atmosphere. Sensor operates in pulse mode measuring actual concentration of gas during 1 second with 20 seconds intervals.

The sensor is equipped with buzzer and diode indicators.

Depending on actual gas concentration the sensor behaves as indicated in table below:

Gas concentration	Module behavior
< I alarm level (normal state)	Green LED blinking
< II alarm level	Red LED blinking
> II alarm level	Red LED lit all the time + audible sound via buzzer

The module is equipped with „TEST” button which allows for triggering of alarm thus providing the means to test the alarming circuitry operation.

RS232 communication

In addition to visual and audible communication the module allows to monitor the operation using RS232 terminals. Each 21 seconds the module transmits the measurements data.

The RS232 communication channel also provides means to calibrate the sensor.

Transmission parameters

Baud rate	115200bps
Parity	8N1

TECHNICAL PARAMETERS

Detectable gases	methane
Maximum concentration	5% v/v.
Sensor sensitivity	>10 mV/% CH ₄
Sensor response time	<30 s
Zero drift	<0.1%v/v /month
Sensitivity drift	<0.1%v/v /month
Power supply	5V DC when connected to USB port 3V DC when operated from battery.
Suggested batteries	2x1.5V AA in series (min. 2600mAh)
Operating current	<0,6mA _{avg} (battery operated)
Transmission	USB (RS232, CDC Class)
Weight	11 g
Dimensions [w x l x h]	30 x 65 x 9 mm

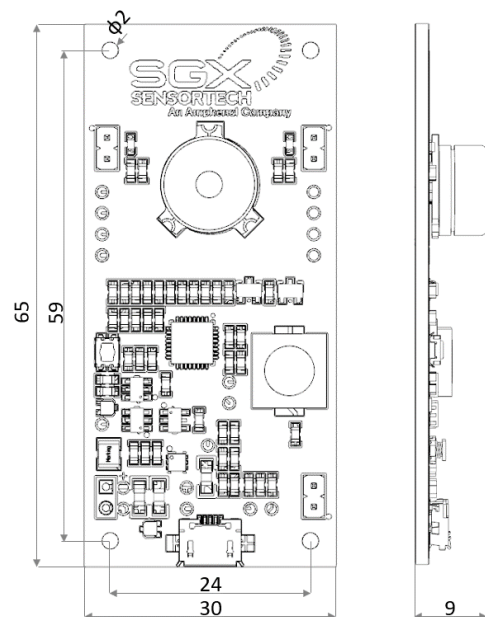

All dimensions are in millimeters unless stated otherwise.

Communication protocol

Frame structure	<p>ADC Code: <code>aaaa, C: b.bb%, Uo: cccmV, T: ddC, S:s\n\r</code> <code>,gdzie:</code> <code>aaaa</code> Wheatstone bridge voltage in ADC code <code>bbb</code> Gas concentration in % vol (based on calibration) with 2 decimals resolution. <code>ccc</code> Wheatstone bridge voltage in mV <code>ddd</code> Temperature in °C <code>s</code> Status: 0: < I alarm level (normal operation) 1 > I alarm level 2: > II alarm level</p>
-----------------	---

Module calibration

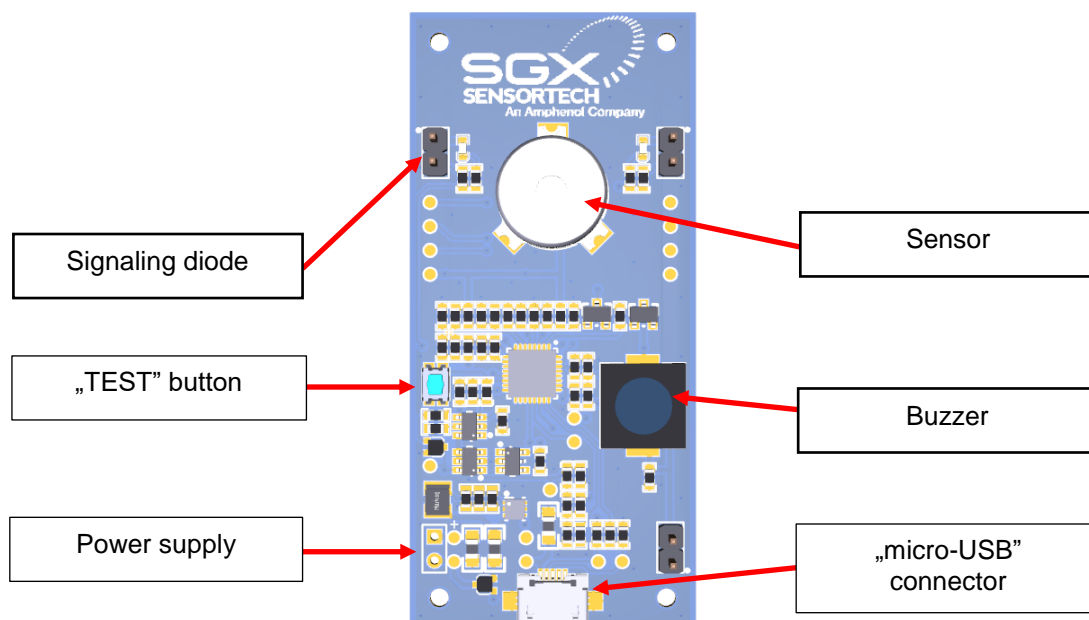

1. Connect micro-USB cord to computer and gas module.
2. Set PC terminal software to 115200bps, 8N1 and select the COM port that appears in device manager.
3. The module will respond to the list of commands listed below and once per ca.21 seconds the most recent measurement results will be transmitted.

List of commands

List of user commands is available after sending a quotation mark "?". The output of this command should result in listing available commands ie.

CAL0 - calibration 0%
CAL1 - calibration 1%
CAL0W - save 0% COEF
CAL1W - save 1% COEF
VER? - soft. version
COEF? - calibration coef.
CON1W - calibration gas level
ALARM - first alarm threshold

Setting up the alarm threshold

In order to set the alarm threshold you need to send the ALARMxxxx, command where xxxx is a concentration of alarm threshold with 0.01 accuracy. The module should respond with „ALARM OK” string.

Readout of calibration coefficients

In case the calibration coefficients would be required the module allows for readout of current settings with “COEF?” command. The output string should look the following way:

CAL0: 0012 CAL100: 0219 CON1: 0100

Programming of calibration coefficients

Calibration coefficients can be read out as well as programmed into the module by using commands:

“CAL0Wxxxx” – coefficient for air,

“CAL1Wxxxx” – coefficient for methane,

“CON1Wxxxx” – concentration of methane for calibration (where xxxx is methane concentration as a multiply of 0.01%, ie. 2.5% equals to 0250).

Exemplary current consumption under standard operation

In standard operation sensor performs a measurement in 20 seconds intervals.

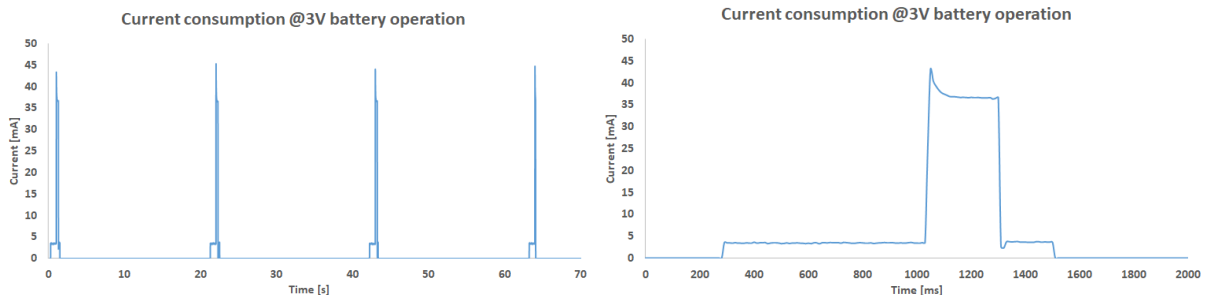

Fig. Current consumption in 70 seconds and single cycle current consumption curve (focused on operating time).

Calibration procedure

Should the sensor require a recalibration procedure, a proper gas flow hood should be used. Gas flow hood is not a part of the module but it is available as a step model allowing for 3D printing by the end-user. The file “Gas_flow_hood v1.0” can be found on www.sgxsensortech.com under Natural Gas Module section.

Sensor should be calibrated using air (preferably synthetic air) and mixture of methane in air* (1-2.5% CH4 in synthetic air). The gas flow hood should be connected with a gas container through a flow meter. The gas flow hood is designed to connect to 6x4mm PU tubing. The pressure should not exceed 2 bar, while flow rate should be limited to a maximum value of 200ml/minute.

In order to perform calibration the following steps have to be performed:

1. Connect micro-USB cord to computer and gas module.
2. Set PC terminal software to 115200bps, 8N1 and select the COM port that appears in device manager.
3. Configure methane gas mixture using CON1W command.
4. Put sensor in air flow (synthetic air). Wait until reading stabilizes (usually 30s ÷ 1 minute) and send CAL0 command – the sensor should respond with “CAL OK” string.
5. Put sensor in methane flow calibration mixture and let it stabilize (usually 30s ÷ 1 minute) and send CAL0 command – the sensor should respond with “CAL OK” string.
6. Send command CAL1Wxxxx, where xxxx is the concentration of gas used for calibration with 0.01 resolution. The sensor should respond with “CAL1W OK” string.

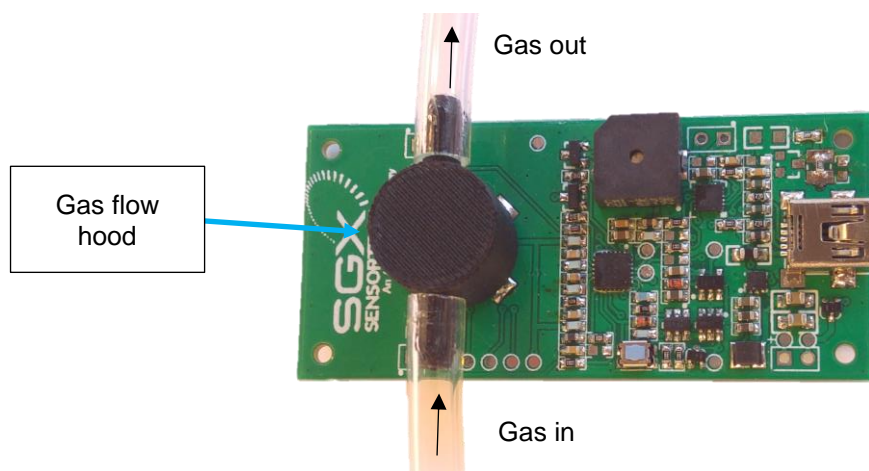

Special conditions

Sensor is equipped with filters allowing it to operate in normal household environment. However sensor should not be subjected to high concentrations of agents containing silicon, sulfide and chlorine compounds (bleach, toilet cleaning agents, silicon greases). If longer exposition to any of the above the overall performance of the sensor might be affected causing limited response to gas. The performance of the module is warranted for 3 months without calibration.

Mechanical dimensions

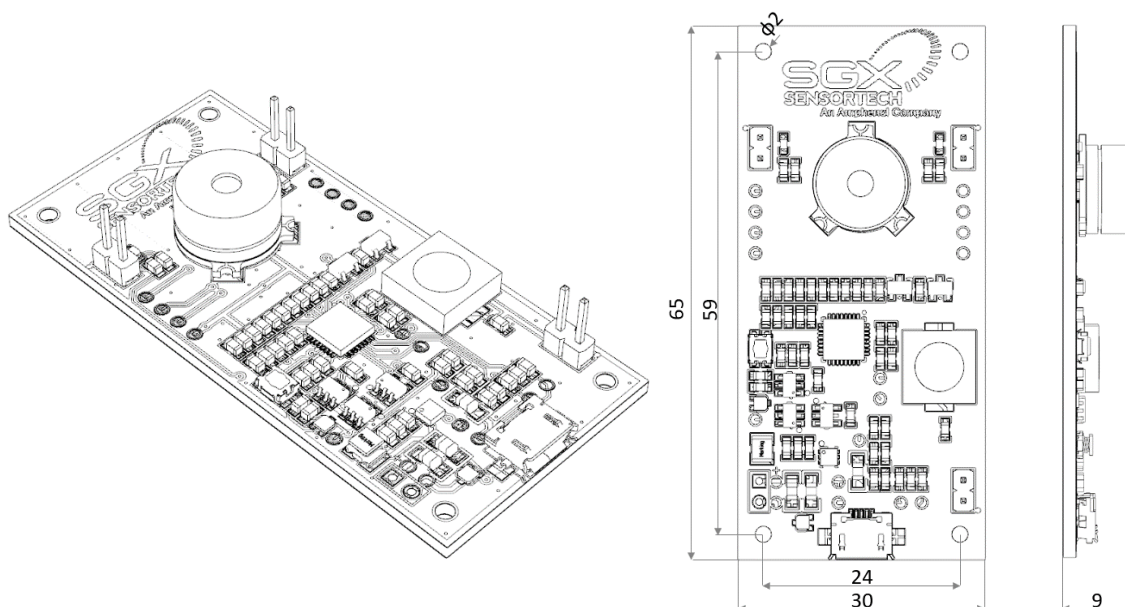

* Gas cylinders can be obtained from recognized companies like: Air Liquide (www.airliquide.com), Air-Products (<http://www.airproducts.com>), Linde (<http://www.linde-worldwide.com>), Messer (<https://www.messergroup.com>)