

MP-7217-TC Combined Flammable and Volume Percent Methane Sensor

The MP-7217-TC gas sensor has been designed to measure Methane over the explosive concentration range and up to 100% by volume.

The explosive range is measured with the sensor in Catalytic mode where the target gas is reacted on the detector bead.

The 100% volume range is measured with the detector bead replaced by a resistor and the compensating bead measuring the target gas concentration by virtue of its change in thermal conductivity.

The sensor also contains an externally digital controllable on-board switch, facilitating the change from the catalytic mode to thermal conductivity mode and back again.

An on-board temperature sensor also provides a temperature output to allow an instrument microprocessor to carry out temperature compensation.

SENSOR FEATURES

- Dual Range i.e. Methane 0-100% LEL; 0-100% Vol.
- Single sensor footprint
- Very low power
- Highly silicon poison resistant
- Highly H₂S resistant
- Mechanically robust to shock
- Low orientation effects
- High quality silicon wafer manufacture

OPERATION

- It is recommended that the detector and compensator be run in a simple Wheatstone bridge circuit at a constant voltage.
- The output of the temperature sensor should be used to compensate for ambient temperature changes particularly in the case of operating in TC mode.
- It is recommended that the changeover switch from Catalytic to Thermal conductivity is software controlled e.g. switching off the catalytic mode when the gas concentration exceeds 60% LEL and switching off the TC mode when the Methane concentration drops below 50%LEL.



INTERFACE DIAGRAM

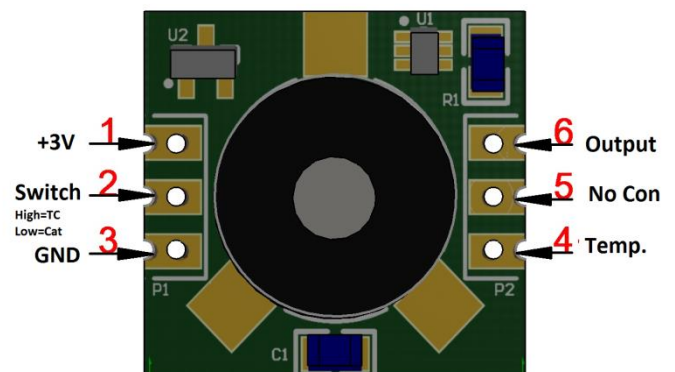

CERTIFICATION

MP-7217-TC	Uncertified
MP-7217	ATEX / IECEx / UL (See MP-7217 Datasheet for more information)

The interface PCB is currently **uncertified** for use in explosive atmospheres. It is anticipated that the design of the interface PCB is incorporated into the design of the instrument. The sensing element MP-7217 is certified as explosion proof (Ex d and Ex ia).

GENERAL DATA

This information relates to the device operating continuously in the recommended bridge circuit.

Operation.....Continuous
Supply voltage (see note 1).....2.9 to 3.1V
Sensor current (at 3.0 ± 0.1V).....39 to 42mA

Typical Sensitivity Methane

(Measured using 1% Methane balance air test gas)

Catalytic mode.....12 mV / % Methane
TC mode.....3 mV /% Methane

Zero offset range in clean air

(at 3.0 ± 0.1V)

Catalytic mode..... ± 20 mV max
TC mode..... ± 50 mV max

Response times (t90) (see note 2)

Catalytic mode..... < 12 seconds
TC mode..... < 10 seconds

Maximum Gas concentration (see note 3)

Catalytic mode..... 5% volume Methane in Air
TC mode..... 100% volume Methane

Long Term Behaviour

Catalytic

Long Term Zero drift (see note 4).....< 1.0 mV/month
Long Term Sensitivity drift (see note 5).....< 0.6 mV/month

TC mode

Long Term Zero & Sensitivity drift: Customer dependent; compensation method used.

Temperature and Linearity

Catalytic: Linear up to a minimum of 4% Methane

TC Mode: See below for Linearity and effect of temperature

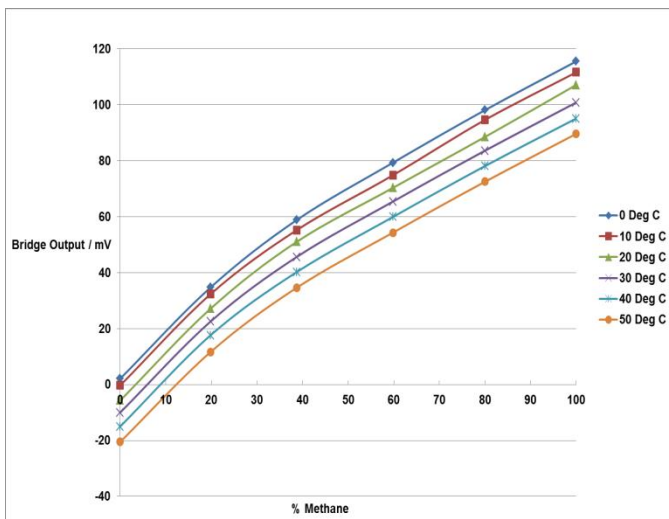

The responses exhibit a quadratic behavior and tests have shown that a 3 point calibration at 0, ~40 & 100% Methane will generate factors which will meet the requirements of

EN60079-29-1 2007 part 5.4.3.2 i.e. within ±3% Methane or ±5% of indication.

MAXIMUM RATINGS (Absolute values)

Input voltages between pins 2 and 3.....3.2 V

Operation, storage in original packaging and shipping:
Temperature.....-40 to +60 °C
Humidity.....0 to 95%RH non-condensing

NOTES

1. The polarity of the supply voltage may be reversed without harm. The only effect is to reverse the polarity of the output signal.
2. Responses measured at 3.0 ± 0.1 V using 1% Methane in an SGX test manifold at 500 SCCM.
3. Exceeding these limits may change the sensitivity to Methane or the zero in air or in extreme cases permanently damage or destroy the sensor. The calibration of the sensor should be re-measured if the sensor voltage has exceeded 3.2 Volts.
4. Whilst operating, to gas concentrations greater than the Lower Explosive Limit.
5. Over 90 days period. Measured at 3.0 ± 0.1 V using 1% methane, over a 90 days period.

IMPORTANT PRECAUTIONS

Read the following instructions carefully before using the MP-7217TC described in this document to avoid erroneous readings and to prevent the device from permanent damage.

Some compounds are known to have detrimental effects on the response of catalytic detector bead to gas.

- I. Long term exposure to silicones (by far the most significant poison), hydrogen sulfide (other sulfur containing compounds), phosphates and organometallic compounds will irreversibly poison the sensor. High concentrations of flammable gas could also permanently affect the response of the sensor in catalytic mode.
- II. Long term exposures to Hydrogen Sulfide can cause temporary or permanent loss of catalytic sensor response. Other vapours such as Halogenated hydrocarbons (e.g. freon, trichloroethylene, methyl chloride, etc.), can cause the same type of effect to a lesser degree.
- III. Specific protection is needed in applications where poisons or inhibitors are present.

SGX strongly recommends using ESD protection equipment to handle the sensor. For any additional questions, contact SGX.

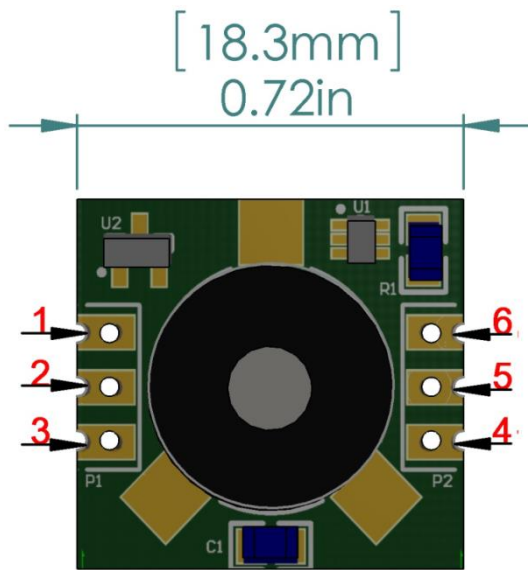

TOP VIEW

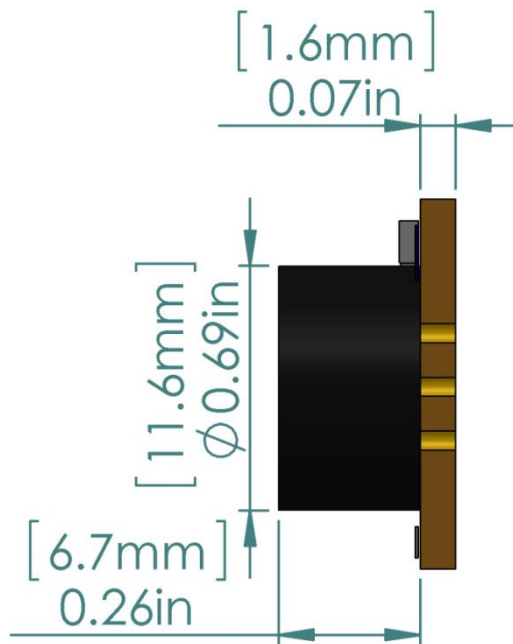

RIGHT VIEW