

INTRODUCTION

This application note gives guidance on the design of electronic circuits for use with SGX Sensortech infrared gas sensors. The information is provided for general advice and care should be taken to adapt the circuits to the particular requirements of the application. By following the recommendations of this application note, the user should be able to achieve excellent performance with SGX Sensortech infrared gas sensors.

Figure 1 shows the outline block diagram of a typical gas detection system using an infrared gas sensor.

The **IR gas sensor** contains a lamp which is pulsed at low frequency by a **lamp drive** circuit. The pulses of infrared radiation reflect internally to provide a long path through the target gas. Pyroelectric detectors (pyros) are used to detect the change in infrared signal. The **active pyro** is sensitive to changes at IR wavelengths which are typically absorbed by the gas being detected. The **reference pyro** is sensitive to changes at a nearby IR wavelength which is not absorbed by the gas being detected.

The small pyro output signals are approximately sawtooth in shape and must be amplified and filtered. A **bandpass amplifier** is used to pass only the fundamental frequency and reduce any pyro noise at other frequencies. The amplifier outputs are roughly sinusoidal in shape.

The **analog to digital converter (ADC)** samples the maximum and minimum of the amplifier outputs to determine the peak-to-peak level. The ratio of peak-to-peak levels for the active and reference channel is used by the **microprocessor** to calculate the actual gas concentration.

Both pyros are also sensitive to background temperature and a **temperature sensor** is necessary so that the microprocessor can compensate the pyro outputs for the effects of ambient temperature. Some gas sensors have an internal temperature sensor. Where this is not present, the electronic circuit should provide a temperature sensor close to the sensor body.

The microprocessor may drive a number of **outputs** depending on the applications. These could include an **LCD display**, a **4 – 20 mA interface**, a number of **alarms** or other outputs as needed.

'Twin gas' sensors (IR15T and IR25T series) are also available containing two active pyros. These allow two different gases such as methane and carbon dioxide to be monitored with a single gas sensor. A small number of sensors are also available without a reference channel (IR31SC/SE) and may be used in applications where lower accuracy is needed. Finally, the IR600 series provide the gas sensor and band pass amplifiers in a single unit.

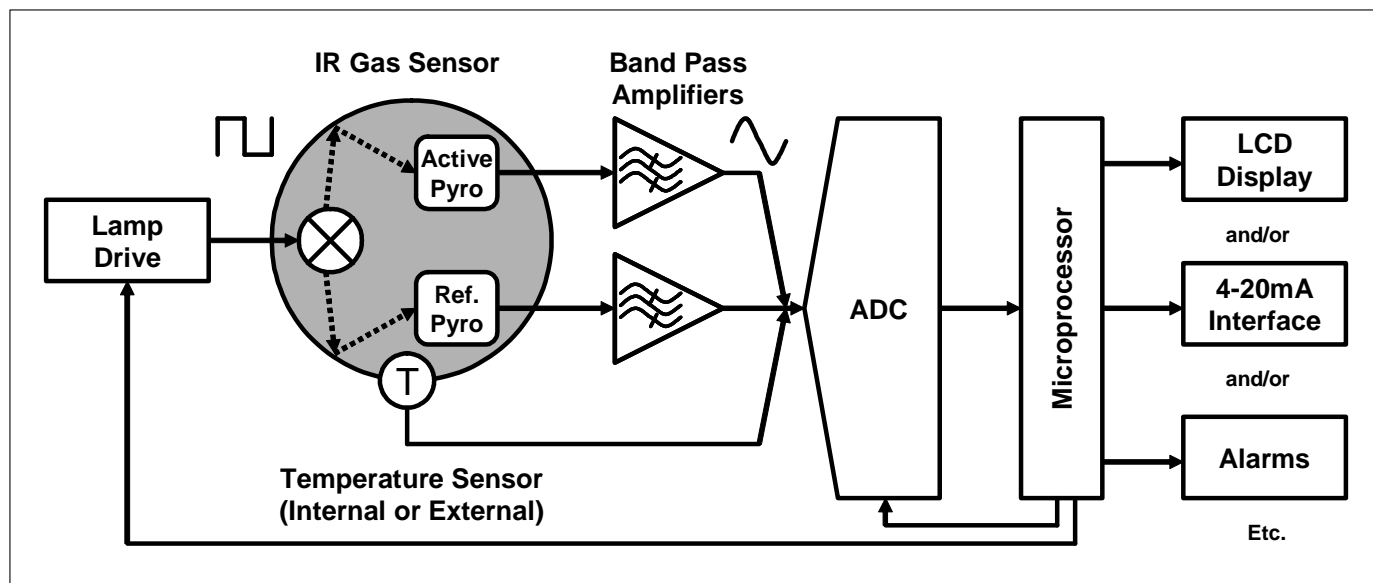

Figure 1 – Block Diagram of Typical Gas Detection System using Infrared Gas Sensor

LAMP DRIVE

Lamp Frequency and Stability

A 4 Hz 50% duty cycle square wave lamp drive waveform is recommended. It is important that the frequency is generated from a crystal controlled source, such as a microprocessor with a crystal reference. Analogue RC oscillators are not stable enough for accurate operation. When using a microprocessor, care should be taken to ensure there is no frequency or phase variation on the lamp drive waveform due to timing variations or interrupts in the software.

If the frequency is increased higher than 4 Hz, the pyro outputs will be reduced. Although a lower frequency will give a higher pyro output, it will also result in a number of other problems for the overall system:

- The ADC sampling rate will also need to be reduced resulting in less noise reduction through averaging.
- Larger capacitors will need to be used in the output amplifiers which may cause certification problems for an intrinsically safe instrument.

SGX Sensortech uses a lamp drive frequency of 4Hz when testing and characterising gas sensors.

Lamp Voltage

The lamp drive peak-to-peak voltage should be between 3.0 V and 5.0 V. A 5.0 V square wave will give maximum infrared emission and the best system performance. Heat from the bulb will also keep the temperature of the optical reflector higher than ambient, which is helpful in preventing condensation in humid environments. For battery powered portable instruments, the sensors can also be operated very successfully with a 3.0 V lamp drive. Although the sensitivity to gas will be smaller, the power consumption will be less and the bulb lifetime increased.

Figure 2 shows how the pyro outputs change with bulb voltage. Table 1 shows typical power consumption at various bulb voltages.

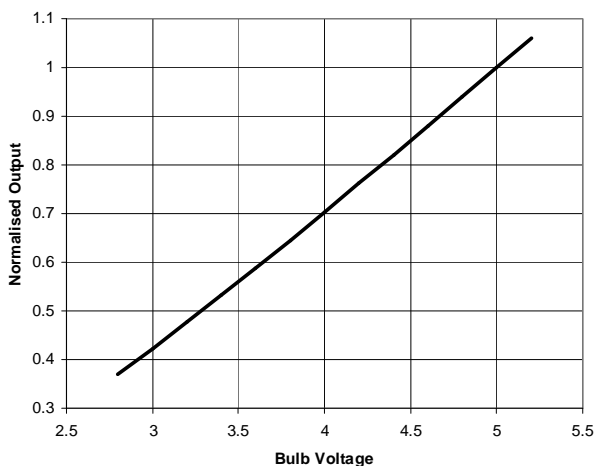

Figure 2 – Pyro Output Voltage vs. Lamp Supply
(IR12GJ Active Channel, Normalised at 5.0 V)

Bulb drive voltage	0	3.0	4.0	5.0	V
Bulb current*	-	45	53	60	mA
Bulb power*	-	135	265	300	mW
Bulb resistance	9	67	75	83	Ω

**Measured at 100% duty cycle*

Table 1 – Typical Bulb Characteristics

It can be seen from Table 1 that the bulb has a very low resistance when cold (turned off). This can cause a current surge at the instant of turn-on which might be undesirable in certain applications. This is mainly a problem when the equipment is turned on from cold – once the bulb is being driven at 4 Hz, it maintains some heat even when 'off' to reduce this effect.

There are several methods that can be used to address this issue if it causes a problem:

- Bias the bulb at about 0.4 V when 'off' to keep it just warm (see optional resistor in the circuits in Figure 3)
- Add a small series resistor
- Use a regulator with a current limit
- Control the duty cycle from the microprocessor at instrument switch on, increasing from 0% to 50% over the first few seconds.

Lamp Circuit Isolation

The bulb current is relatively large compared to the pyro output signals. Careful circuit design and layout is required to prevent breakthrough of the bulb switching pulses causing voltage steps on the output waveforms. Care should be taken to ensure the lamp return current does not flow through the sensitive pyroelectric amplifier earth. The bulb current must also not use the same return path as the ADC or temperature sensor, otherwise it may cause different voltage offsets depending on whether the bulb is on or off at the ADC sampling point.

It is strongly recommended that separate voltage regulators be used for the bulb drive and the output signal circuit. The bulb voltage can be switched using a MOSFET with a low RDS on resistance (e.g. Si2515BDS). Another method is to use a voltage regulator with a shutdown control which can be turned on and off at 4 Hz. When using low dropout regulators, it is important to follow the device manufacturer's recommendations about input and output capacitors to maintain stability of the bulb voltage.

Figure 3 shows some example circuits for driving the bulb.

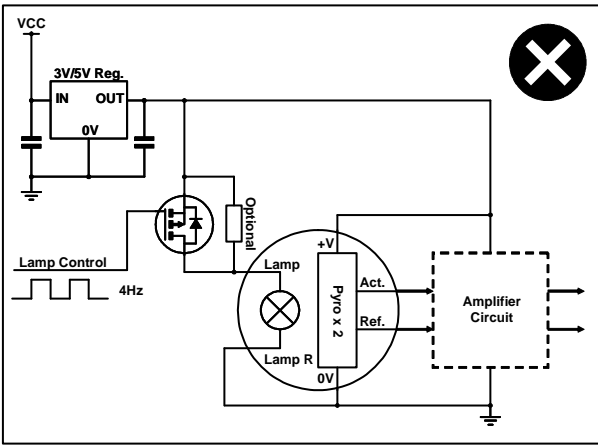

Figure 3a – Common Voltage Regulator with MOSFET Switch

Not recommended – Lamp switching current will break through to pyro outputs.

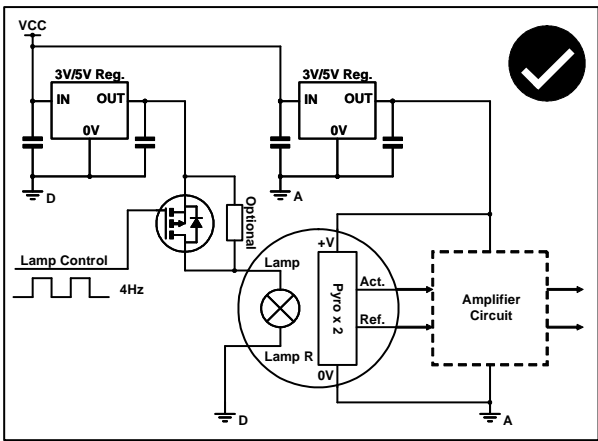

Figure 3b – Separate Voltage Regulators with MOSFET Switch

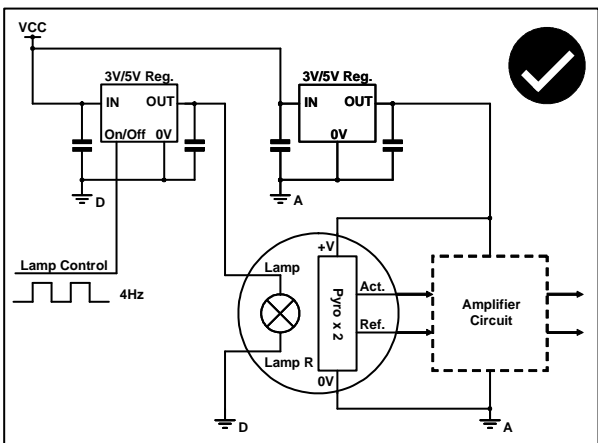

Figure 3c – Separate Voltage Regulators Using Shutdown Control

PYRO SUPPLY AND OUTPUT LOAD

The pyroelectric detectors inside the gas sensor convert a change of infrared radiation to electrical current. The pyro supply voltage can range from 3 V to 15 V. However, in gas sensors containing a Temperature Sensor IC, the supply voltage should be limited to 10 V.

The pyroelectric material has a very low output and is internally buffered using a Field Effect Transistor (FET) in a source follower arrangement. It is necessary to provide an external current load of between 10 and 100 μA ; the optimum for lowest noise is about 20 μA . The detector output typically has a DC bias between 0.4 V and 1.5 V, so for most single supply applications a 47k resistor can be connected from the sensor output to ground (Figure 4a).

If the gas sensor experiences very sudden changes in ambient temperature, it is possible for the DC bias of the detector output to try to go negative. If a well decoupled and clean negative supply rail is available, then a larger load resistor could be connected to the negative rail, e.g. 330k to -5 V (Figure 4b).

Another approach is to use a 20 μA current source from the negative supply as shown in Figure 4c. This can be achieved using an n-channel JFET (e.g. 2N4339) and a resistor.

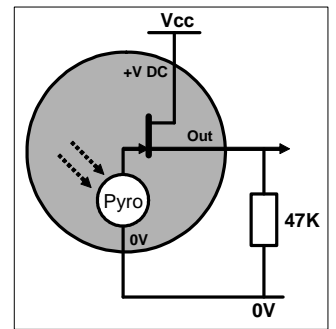

**Figure 4a
Pyro Output
(simple load)**

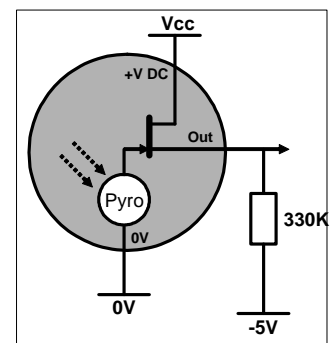

**Figure 4b
Pyro Output
(negative supply)**

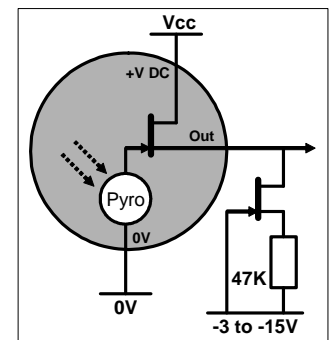

**Figure 4c
Pyro Output
(current source)**

BAND PASS AMPLIFIER

The output of the pyroelectric devices is very small, typically less than 50 mV, and must be amplified. The amplifier should be mounted as close as possible to the gas sensor to reduce pickup of noise and other electromagnetic interference. The amplifier should pass the wanted 4 Hz signal and reject other frequencies.

If the bandwidth is too narrow, the filters may be very sensitive to component tolerances and temperature variation. However, if the bandwidth is too wide, the circuit will pass too much unwanted noise from the pyros. This will result in poor signal-to-noise ratio and fluctuation of the instrument reading.

Figure 6 shows a typical circuit for amplifying and filtering the pyro outputs using a single 3 V supply. R1 is the pyro load resistor. There are two high-pass corners formed by C1 with R2//R3 and C2 with R4. A single low-pass corner is formed by C3 with R5. The circuit gain can be changed by changing the value of R5. However, the product of C3 x R5 must be kept constant to maintain the same frequency response. The circuit gain should be chosen to maximise the sensor outputs without causing clipping. Take account of the manufacturing variation of the output given in the data sheets.

The frequency response of the amplifier circuit is shown in Figure 5. In order to keep the responses of both channels the same, the resistor tolerances should be 1% or better and the capacitors should be 10% or better. Care should be taken in choosing the capacitors as many high value devices have very poor tolerances.

The operational amplifier should be chosen for good noise performance below 10 Hz. If the gain is high, then a low offset is necessary to ensure the output is biased in the middle of the supply rails.

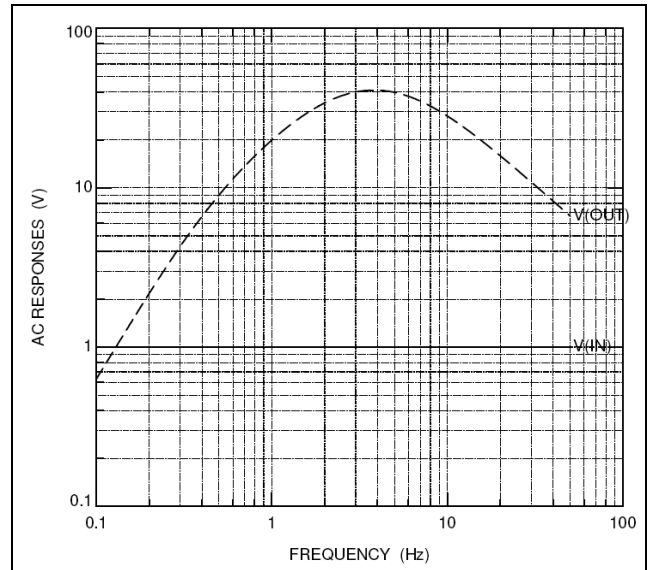

Figure 5 – Frequency Response of Band Pass Amplifier Circuit

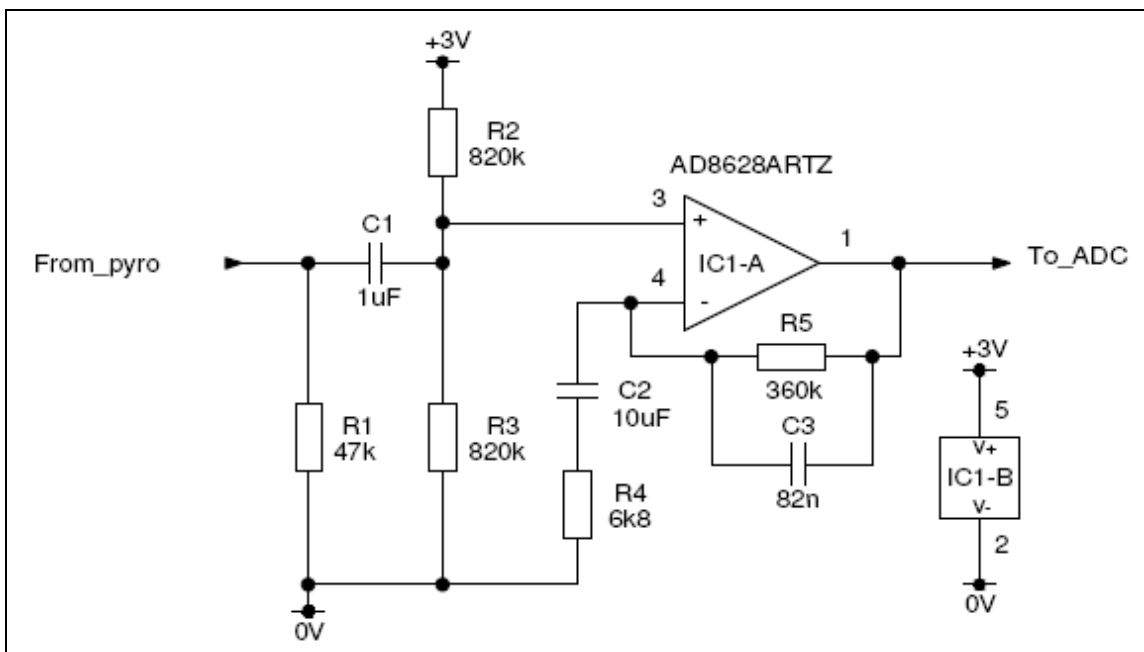

Figure 6 – Typical Band Pass Amplifier Circuit

TEMPERATURE SENSOR

Series 1 single gas sensors do not contain a temperature sensor so it is necessary to mount a suitable sensor as close as possible to the gas sensor body. Series 2 and twin-gas sensors contain an integrated device for temperature monitoring as described in Table 2. Example circuits of how the temperature sensors should be connected are shown in Figure 7. It is strongly recommended that the pyro and temperature sensor supply and ground be kept separate from the bulb supply and ground.

Table 3 shows example values of the change in output with temperature. The equations can be used to calculate the temperature from the voltage seen at the ADC. Alternatively the equations can be used to generate a look-up table. Using a look-up table is often the easiest approach when using an embedded microprocessor.

Gas Sensor Type	Temperature Monitor	Characteristic
Twin Gas Sensor	10k Thermistor (internally connected to pyro 0 V)	Beta Value 3892 <i>Betatherm 10k3A1B</i>
Series 2 Single Gas IRxxEx	10k Thermistor (internally connected to pyro 0 V)	Beta Value 3380 <i>Murata NCP18XH103J03RB</i>
Series 2 Single Gas IRxxGx	IC Sensor (internally sharing pyro Vcc and 0 V)	$V = 424 \text{ mV} + (6.25 \text{ mV}/^\circ\text{C} \times \text{Temp}^\circ\text{C})$
IR600 Head	IC Sensor (internally sharing the 5 V and 0 V)	$V = 500 \text{ mV} + (10 \text{ mV}/^\circ\text{C} \times \text{Temp}^\circ\text{C})$

Table 2 – Types of Integrated Temperature Monitors

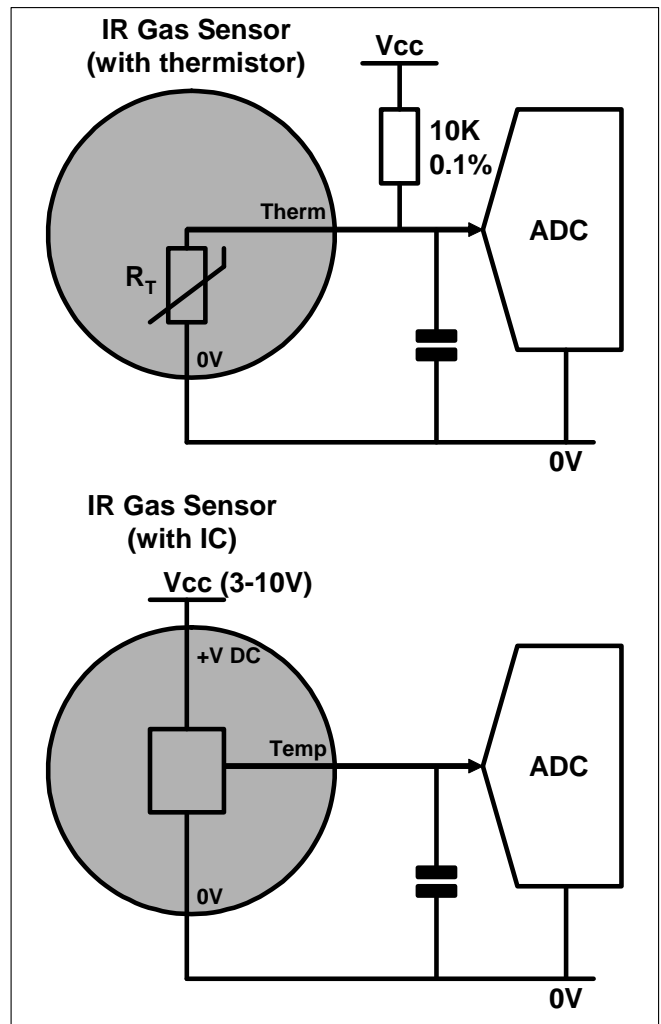

Figure 7 – Example Temperature Monitor Circuits

Temperature	Twin Gas (Thermistor)		IRxxEx (Thermistor)		IRxxGx	IR600
	Resistance	Voltage*	Resistance	Voltage*	Voltage	Voltage
-30°C	176.683 k	4.732 V	113.3471 k	4.595 V	0.2365 V	0.20 V
-20°C	96.974 k	4.533 V	68.2367 k	4.361 V	0.2990 V	0.30 V
-10°C	55.298 k	4.234 V	42.5062 k	4.048 V	0.3615 V	0.40 V
0°C	32.6508 k	3.828 V	27.2186 k	3.657 V	0.4240 V	0.50 V
+10°C	19.9035 k	3.328 V	17.9255 k	3.210 V	0.4865 V	0.60 V
+20°C	12.4937 k	2.777 V	12.0805 k	2.736 V	0.5490 V	0.70 V
+25°C	10.0000 k	2.500 V	10.0000 k	2.500 V	0.58025 V	0.75 V
+30°C	8.0560 k	2.231 V	8.3145 k	2.270 V	0.6115 V	0.80 V
+40°C	5.3240 k	1.737 V	5.8336 k	1.842 V	0.6740 V	0.90 V
+50°C	3.6010 k	1.324 V	4.1609 k	1.469 V	0.7365 V	1.00 V
+60°C	2.4871 k	0.996 V	3.0143 k	1.158 V	0.7990 V	1.10 V
+70°C	1.7516 k	0.745 V	2.2275 k	0.911 V	0.8615 V	1.20 V
Recommended Equation	$T = 107.3158 - 60.9514 \times V + 16.01841 \times V^2 - 1.93628 \times V^3$		$T = 117.9263 - 65.8867 \times V + 16.29971 \times V^2 - 1.93821 \times V^3$		$T = \frac{(V - 0.424)}{0.00625}$	$T = \frac{(V - 0.5)}{0.01}$

* Assumes 5 V supply with 10k pull-up resistor

Table 3 – Typical Responses of Temperature Monitoring Devices

ANALOG TO DIGITAL CONVERTER

Number of Bits

The Analog to Digital Converter (ADC) is used to sample the amplified pyro signals and also the temperature sensor. The number of bits of resolution required will depend on the application. However, several factors must be taken into account:

- Absorption of the chosen gas
- Amount of averaging in the microprocessor
- Resolution required for the application

In some applications, a 12-bit ADC is sufficient. However some high accuracy applications will need 14 or 16 bits of ADC resolution.

ADC Reference

A clean ADC reference and ground should be provided. The reference should be chosen for low noise below 10 Hz. Take care to isolate the ADC supplies from the bulb drive to prevent coupling of the bulb switching transients.

ADC Timing

Figure 8 shows some typical timing waveforms. There is a delay between the bulb switching point and the maximum or minimum of the signal response. This delay is typically around 25 ms but will depend on the model of gas sensor being used. The delay is also related to the output level of the pyro devices and it can be seen that if the bulb drive is reduced from 5 V to 3 V the delay time will increase.

When using gas sensors which have a large difference between the active and reference signal levels (e.g. IR12/22GJ and similar models), a small difference in the delay time for the active and reference peaks will be observed. In this situation the ADC should sample at the average delay time, or use a different delay time for each channel.

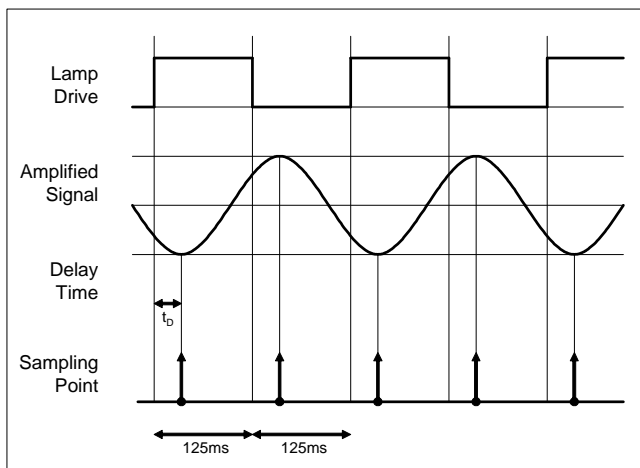

Figure 8 – ADC Timing

MICROPROCESSOR

The choice of microprocessor will depend on the requirements of the application. Some microprocessors have integrated ADCs which will reduce size and cost of the instrument. The microprocessor will need to store a set of coefficients in order to calculate the gas concentration using the method described in Infrared Application Notes 2 and 3.

A means of calibrating the device will also be required. The simplest method uses two push-button switches (“zero” and “span”) that are monitored by the microprocessor software at regular intervals.

The “zero” button is pressed during exposure to a gas containing zero concentration of the target gas. Typically, a source of dry nitrogen is used for this. The software will then calculate the “zero” reading and store the value in non-volatile memory, to be used during future calculations.

The “span” button is pressed during exposure to the target calibration gas. The software will then calculate the “span” reading and store the value in non-volatile memory, to be used during future calculations.

It is generally recommended that a gas sensor instrument be switched on and allowed to temperature stabilize for at least 30 minutes before performing calibration.

NOISE REDUCTION

A good circuit design will enable you to get the optimum performance from SGX Sensortech infrared gas sensors. Be careful to avoid common design issues which might lead to increased noise or other performance effects. Examples of possible problems are:

- Supply regulator noise*
- ADC reference noise*
- Op amp noise*
- Unstable 4 Hz lamp drive or ADC sampling point (possibly caused by software interrupting)
- Poor channel matching over temperature (poor component tolerances)
- Electromagnetic pickup due to poor earthing or long tracks on sensor outputs
- Breakthrough of lamp switching transients caused by poor earthing

* When selecting devices, carefully consider the noise performance between 1 and 10Hz.

Noise can also be reduced by averaging the ADC reading. Averaging over n samples will give a \sqrt{n} improvement in the standard deviation of the signal. However it will also cause an increase in the response time to change of gas concentration.

For more information about SGX Sensortech infrared gas sensors, refer to all the application notes available from www.e2v.com or contact your local SGX Sensortech representative.